

- For control of heating or cooling in zone control systems
- 0...10 VDC, 1 mA or 3-point 24VAC, 1A
- Setpoint 0...40 °C
- P or PI mode selection
- Occupancy mode control
- Change-over function
- External sensor TG-K340B (Optional)



Technical data

<b>Electrical data</b>	Nominal voltage	AC 24V 50/60 Hz
	Power supply range	AC 19.2 ... 28.8V
	Power consumption	2VA
<b>Functional data</b>	<b>Input</b>	
	External sensor	Type NTC, 10kOhm@40°C, TG-K340B [Optional]
	Occupancy	Potential-free contact
	<b>Output</b>	
	Control signal	0...10 V DC, 1 mA or 3-point AC 24V, 1A
<b>Settings</b>	Setpoint	0...40°C (Base setpoint value is 22°C)
	P-band	0.5...50 K
	Reset-time(I-time)	2 or 20 min, see jumper setting below
	TrimPot(Occupancy)	+/-6°C
	<b>Working conditions</b>	Degree of protection
<b>CE</b>		CENELEC EN 61000-1 and EN 61000-3
	Ambient conditions	0 ... +50°C
	Non-operating temperature	-10 ... +60°C
	Ambient humidity range	max. 90% r.h. , non-condensing
	<b>Dimensions</b>	Dimensions (L x H x D)

Function selection (jumpers)

Fig.1

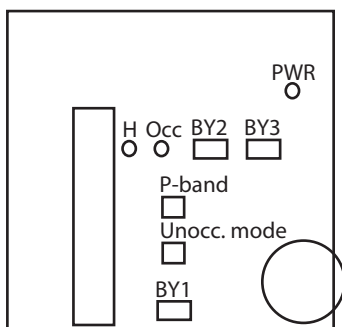

- Jumper BY1      Right      = Internal sensor (**factory setting**)  
                         Left        = External sensor
- Jumper BY2      Closed     = Reset time (I-time) is 2 min  
                         Open      = Reset time (I-time) is 20 min (**factory setting**)
- BY2 setting valid only when jumper BY3 is set to PI-function
- Jumper BY3      Closed     = P-function  
                         Open      = PI-function (**factory setting**)

To obtain open position place the jumper on one pin only.

## Product function

**Sensor** The controller has a built-in temperature sensor element. External sensor TG-K340B can be connected. See function selection for jumper setting.

**Occupied/Unoccupied mode** The setpoint can be adjusted in accordance to an input for occupancy. On open contact, the thermostat setpoint is determined by the setpoint adjuster (occupied mode). On closed contact, the setpoint is determined by an internal trimpot (unoccupied mode). The base setpoint value is 22 °C.. It can be reset depending on the setting of the potentiometer "Unoccupied", and is adjustable with a span of +/-6°C. **[Factory setting = 3 (25°C, 19°C)]**

Position	0	1	2	<b>3</b>	4	5	6
Cooling setpoint	22	23	24	<b>25</b>	26	27	28 °C
Heating setpoint	22	21	20	<b>19</b>	18	17	16 °C

**Change-over** An input can be connected to a closing relay contact. On closed contact the controller works with heating output and on open contact cooling.

**Indications** Green LED (PWR) : for activated output (see Fig. 1)  
 Red LED (H) : lit for heating, not lit for cooling  
 Green LED (Occ) : lit for occupied mode, not lit for unoccupied mode.

**Setpoint** Adjust with knob that extends from the lower right of the casing. The knob setting can be mechanically fixed with a latchscrew located under the front cover.

**Setpoint calibration** The knob rim with the scale can be detached from the hub and remounted in new position. Grip across the rim and pull out at the same time as maintaining an inward pressure on the hub. When re-mounting, make sure the parts snap together properly.

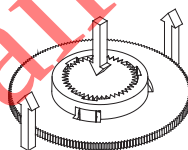

## Dimensions[mm] & Terminals

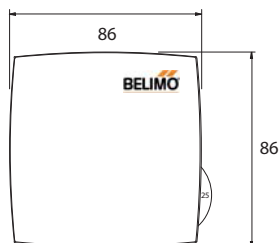
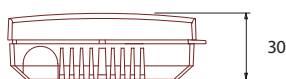

1	AC 24V supply
2	System neutral
3	3-point output - neutral
4	3-point output - open
5	3-point output - close
6	0...10V DC control output
7	Signal neutral
8	Change-over input
9	Occupancy input
10	External sensor

Terminals	7 & 8	7 & 9	7 & 10
Function	Change-over	Occupancy	External sensor

Terminals 7 & 8	Short	Open	Sensor
Function	Heat	Cool	Automatic control